

GardenLife®

Need advice? Can't decide?
We're here to help, just call:

0131 660 6333



Best online prices for log cabins guaranteed

We believe our products are of the highest standard and that our prices cannot be matched on a like for like basis. If you find a GardenLife cabin on any other website for a lower price we'll match that price!

5 year warranty on all timber buildings

GardenLife log cabins come with a full five year warranty that guarantees replacement of any component parts if they are found to be defective.

Completely free shipping to UK mainland

If you live on the UK mainland and order a log cabin or timber garden building from our site it will be delivered completely free of charge!

£50 cashback & £100 off for friends & family

Purchase any GardenLife log cabin or timber building and claim £50 each time you refer friends and family! There's no limit to how much you could earn and each person you refer gets £100 off their purchase!

On site construction available on request

Worried about building your log cabin? Don't be, GardenLife provide an on site construction service throughout much of the UK. Let our trained professionals take the strain and call for a quote.

Installation manual

Montageanleitung • Notice de montage • Istruzioni per il montaggio • Manual de montaje

Log cabin FRJ28-3030

Blockhaus • Maissonnette en poutres • Casa di travi • Casa de jardin

Width 300 x Depth 300 cm

Breite/Tiefe • Largeur/Profondeur • Lunghezza/Profondità • Ancho/Profundidad

Log thickness 28 mm

Bohlenstärke • Épaisseur des murs • Spessore delle pareti • Grosor de pared



The producer shall have the right to make technical changes to the product • Technische Änderungen vorbehalten • Le producteur réserve le droit d'effectuer des modifications techniques au produit • Il produttore mantiene il diritto di apportare modifiche tecniche al prodotto • Reservado el derecho a modificaciones técnicas



Garden house painting and maintenance

Wood is a natural material, growing and adapting depending on weather conditions. Large and small cracks, colour tone differences and changes, as well as a changing structure of wood are not errors, but a result of wood growing and a peculiarity of wood as a natural material.

Unprocessed wood (except for foundation joists) becomes greyish after having been left untouched for a while, and can be turn blue and become mouldy. To protect the wooden details of your garden house, you must immediately process them with a wood preservative.

We recommend that you cover the floor boards in advance with a colourless wood impregnation agent, especially the bottom sides of the boards, to which you will no longer have access when the house is assembled. Only this will prevent moisture penetration.

We definitely recommend that you also process the doors and windows with a wood impregnation agent, and do that namely both inside and outside! Otherwise the doors and windows can become twisted.

After the house assembly is completed, we recommend for the conclusive finishing a weather protection paint that will protect wood from moisture and UV radiation.

When painting, use high quality tools and paints, follow the paint application manual and manufacturer's safety and usage instructions. Never paint a surface in strong sunlight or rainy weather. Consult a specialist regarding paints suitable for unprocessed softwood and follow the paint manufacturer's instructions.

Having been properly painted, your garden house's lifetime will increase substantially. We recommend that you inspect the house thoroughly once every six months.

2 Preparation for assembly

Tools and preparation of components

To assemble the garden house, you will need the following tools:



assembly aid



ladder



hammer

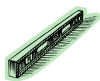

water-level



screwdriver



saw



knife



measuring tape



pliers



drill

ADVICE: To avoid splinters, we recommend that you wear the corresponding protective gloves during the assembly process.

Preparation of components:

Sort the components based on the wall plans (see Technical specifications) and place them at the four sides of the house in the installation sequence.

ATTENTION: Never place the components directly on grass or a muddy surface because it will be very difficult or even impossible to clean them up later!

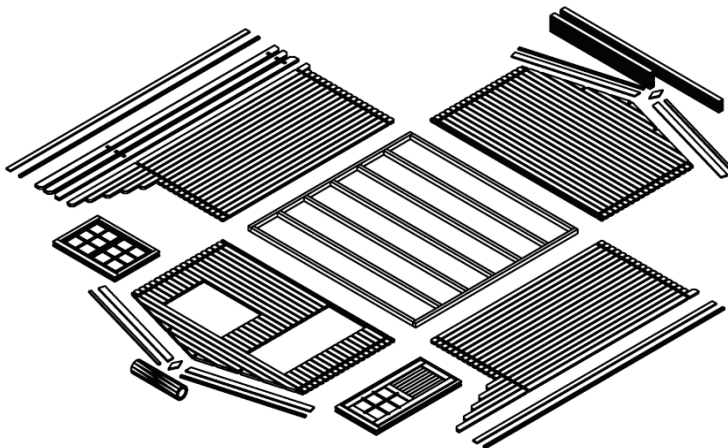

Foundation

A good foundation is the most important aspect guaranteeing the duration and safety of your house. Only a completely level and bearing foundation will ensure problem-free installation of the house, its stability and especially the matching of the doors. With a good foundation, your house will stand for many years more.

Prepare the foundation so that its upper edge extends from the ground to a height of at least 5 cm. At the same time make sure that there are sufficient air apertures under the house floor for ventilation.

We recommend the following foundation options:

- Strip or spot foundation
- Foundation from concrete or pavement slabs
- Cast concrete bed

Prepare the foundation so that the foundation joists are propped up on every side with intervals not exceeding 50-60 cm.

Consult an expert in this field or have the foundation prepared by specialists.

3 Garden house assembly

ATTENTION:

- You will find included in the house package one spare log (longest wall log).
- You will find included in the house package one spare board (longest roof or floor board).
- The house package also includes 2-3 marked hitting blocks (wall profile approximately 20-30 cm long).

All of the details listed above ARE NOT mentioned in the specification list.

- The drawings have the details marked with three-digit position numbers. The exact positions of those details that have the third digit "x" can be found in the specification list.

Base frame (Foundation joists)

The base frame of the house must be completely flat and level to ensure that the installation proceeds without problems.

ATTENTION: different house can have different foundation placements – see the appended base frame drawing (in Technical specifications)!

Place the impregnated foundation joists on the prepared foundation in accordance with the drawing at equal intervals. Make sure that the joists are level and prior to screwing them together.

ADVICE: It is recommended to place between the foundation joists and foundation a damp-proof course that will protect the house from moisture and decay.

ADVICE: To ensure protection from wind and storm, it is recommended to attach the foundation joists to the foundation (for this, you can use for instance metal angles, anchors, etc.). The corresponding materials are not included in the supplied kit!

Installation of foundation joists:

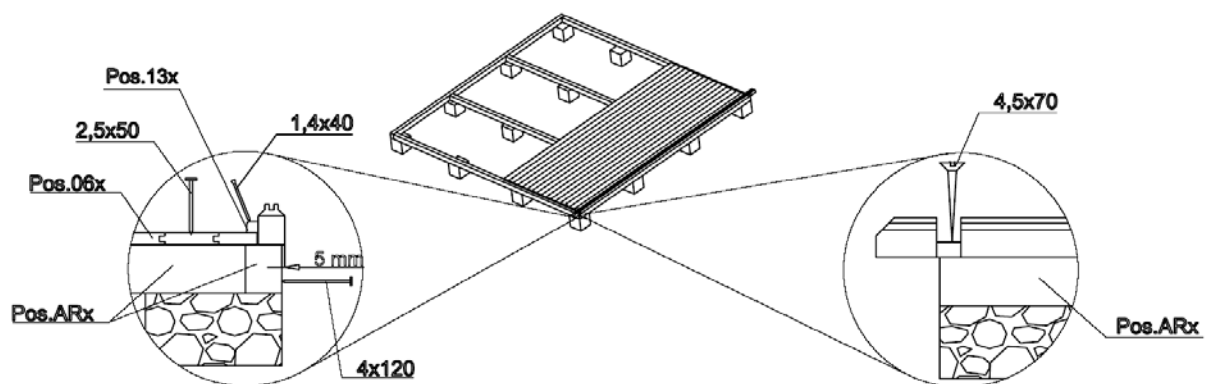

Floor

Install the floor right after foundation bearers have been placed into position and screwed together. Cover the floor for the assembling time thus avoiding unnecessary smudging on the floor.

Start assembling the floor as shown on the drawing moving in both directions. If necessary, cut the last boards of the sides to suitable width.

When placing floor boards, please note that the boundary line of floor boards must be all around the floor 27 mm inside from external edge of foundation bearers. It will guarantee that the first layer of wall logs will fit on the base frame.

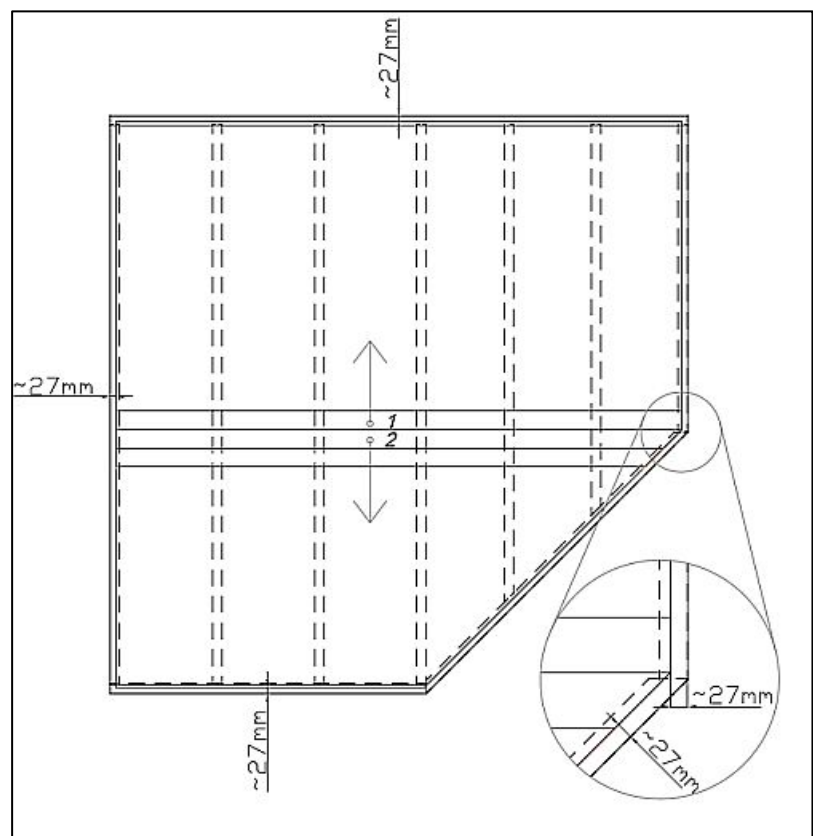

Installation manual

Floor boards should be fixed to every foundation bearer with nails 2,5x50 mm. For nicer finish we suggest to nail the boards from top part of the tongue so the head of the nail will be covered with groove of next board.

The final operation is the fitting of the floor beadings to cover the spaces between the floor boards and walls. If necessary, cut the floor beadings to the suitable length.

ATTENTION: Depending on the climate at the house location, the floor boards can either swell or diminish. If the floor boards are very dry while the climate is damp, they will easily absorb moisture. In this case, the floor boards should not be attached very densely to avoid likely bulging. Leave some space (1-2 mm) between the floor boards to allow for swelling. But if your climate is warm and dry, you can install the boards densely because they will become drier and spaces may appear between them.

Walls

When installing the walls, it is important to remember that:

- The logs are always assembled with their tongue upwards!
- If necessary, use the hitting block and hammer! Never directly hit the tongue with the hammer!

Install the walls in accordance with the appended wall plans (see Technical specifications).

First of all place half logs of front and back wall at the correct location and attach them with screws to the foundation joists. Then install the side wall logs. Make sure that the first layer of logs extends a bit over the foundation joists: the logs must extend over the joists by some 3-5 mm. You will thus protect the house from moisture, allowing the free flow of rainwater into the ground.

ATTENTION: After the first layer of logs, measure the diagonal lengths and, if necessary, re-install the logs. Only if the diagonal lengths are completely equal is the base frame rectangular and you can mutually attach the logs.

The first layer of logs:

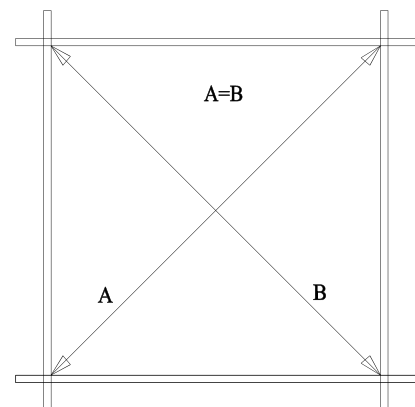

Continue the installation of the walls by strongly forcing the wall logs into one another. If necessary, use the hitting block and hammer. At the same time, do not forget to begin the installation of the door and windows. You should definitely begin the door installation after the 5th-6th layer of logs.

Door and window

Doorframe:

- If it is a double door, the doorframe is supplied in separate parts due to transportation requirements and you will have to begin by assembling it.
- To do this, place together the 4 parts of the frame and screw them onto one another.
- Make sure that the part of the frame with the deeper notch is installed upwards. The lateral jamb parts have hinges and are mirrored.
- It is recommended to install the leaves later.
- If it is a single door, its frame and leaf are supplied already assembled.

Doorframe installation (Only necessary for a double door!):

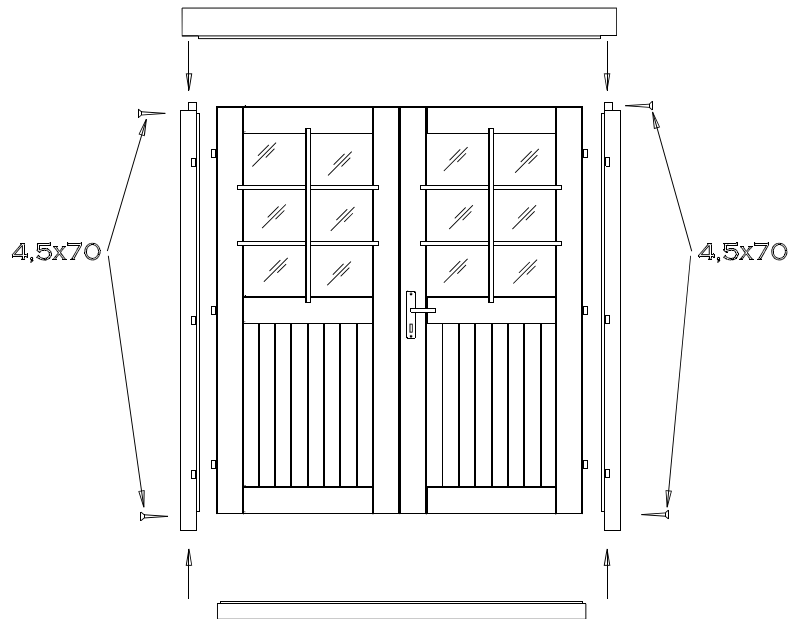

Door installation:

The doorframe is placed at the formed aperture and pushed with force onto the lower log. If it is a double door, place the leaves on the hinges now. To open and close the door, fit the separately packaged lock and handle.

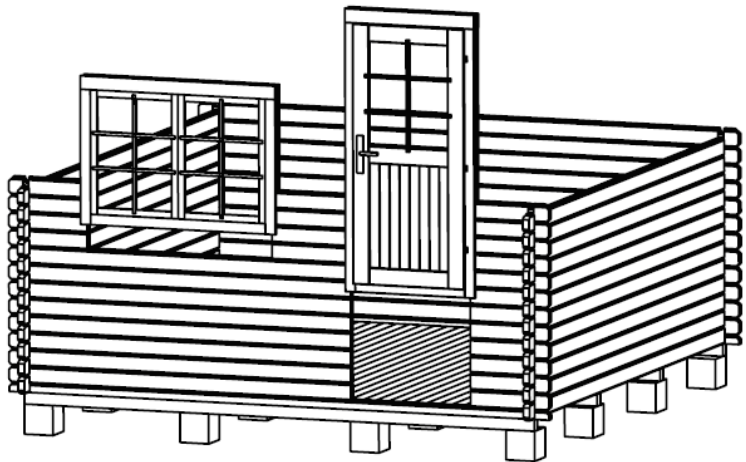

Window installation:

Continue with the installation of the wall logs until you reach the window height. The wall plans (see Technical specifications) show how many logs go under the window. Install the window similarly with the door. Just like the door, push the window frame with the window into the window aperture onto the lower log, applying force. Make sure that the window is not fitted backwards (topsy-turvy).

ADVICE: Definitely make sure that the windows and doors open in the proper direction. The doors always open from the inside **to the outside**. The revolving-tilting windows open **to the inside**. The revolving and the slinging windows open **to the outside** (the window handles are on the inside).

ATTENTION: It is not necessary to fix the doors and windows to the wall logs! If you wish to do this, it will be sufficient to fix them with a couple of screws in the lower part of the frame because as they dry, the wall logs will begin subsiding.

You can conduct the final adjustments of the doors and windows only some 2-3 weeks after the house installation, when the house will have become adapted to weather conditions and its logs settled.

Roof

Before installing the roof, make sure that the house is completely level. Use the water-level to check all walls.

ATTENTION: When placing the roof, use a stable ladder. Do not step on the roof as the structure is suitable to sustain only an even load (snow, wind, etc.), and not a point load!

Install the purlins PR1 on the walls so that the notches will cover the corners of the walls. Fixate the purlins to the central fixing block (Pos. 153) and on the walls. Now place the pos. PR2 and PR3 from the top to the purlin and from the bottom to the upper wall log. Fixate the U-Profile boards between the purlins and on the walls.

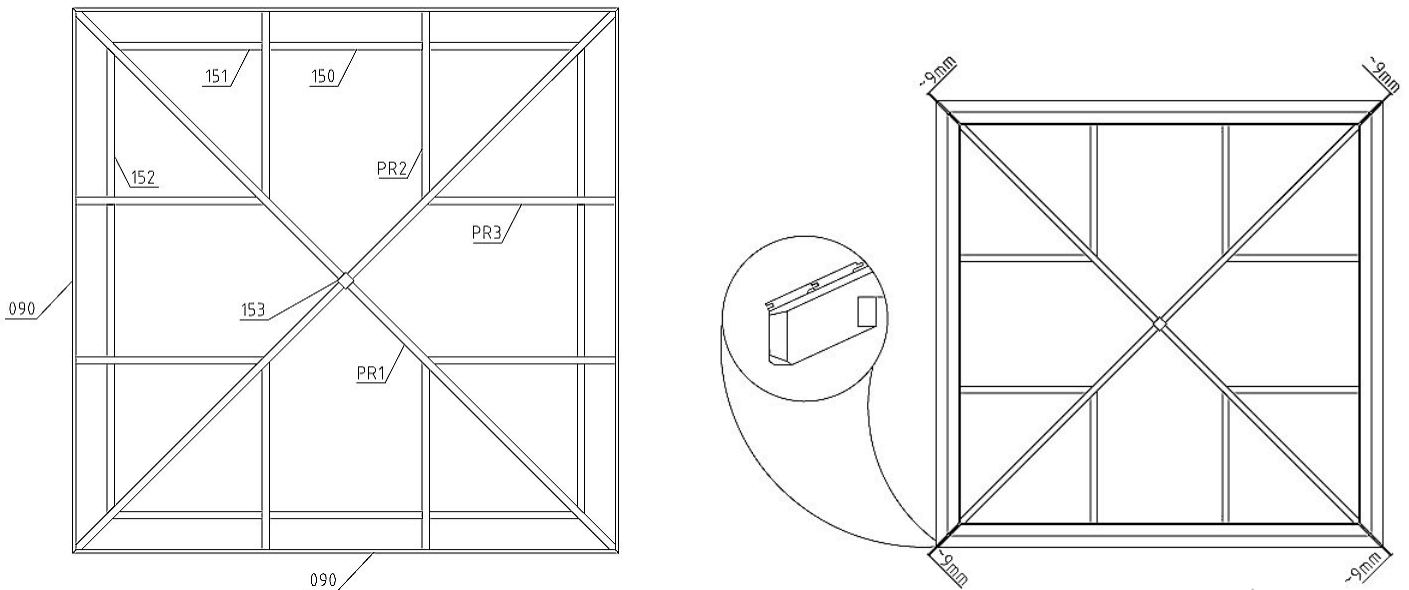

Start placing the roof boards with the longest board from the bottom. Put the groove side downwards that the bottom side of the board will meet the ends of the rafters. It is recommended to place the roof boards in turns on the all sides of the roof. 3-5 roof boards in one turn. Fixate the roof boards on the rafters with 2,5x50 mm nails.

After you have installed the roof boards, cover it with roof covering material (not included in house kit). It is necessary to avoid the bulging of the roof boards due to wetness.

Storm braces (NB! Not included in some house option kits!)

Attach the storm braces (if included in the supplied kit) to the inner sides of the front (2 units) and back (2 units) walls with the supplied bolts. It is important for the logs to be drilled through in advance. Please keep the distances indicated in the drawing so that no problems occur due to wood swelling or diminishing.

ADVICE: Make sure that the storm braces are attached to the apex log from above and to the middle of the first full-length wall log from below. If necessary, shorten the upper ends of the slats.

Do not turn the screws tightly so wood can further swell or diminish.

With the house having settled, you should adjust the attachments so the wall logs can settle.

Installation of storm braces:

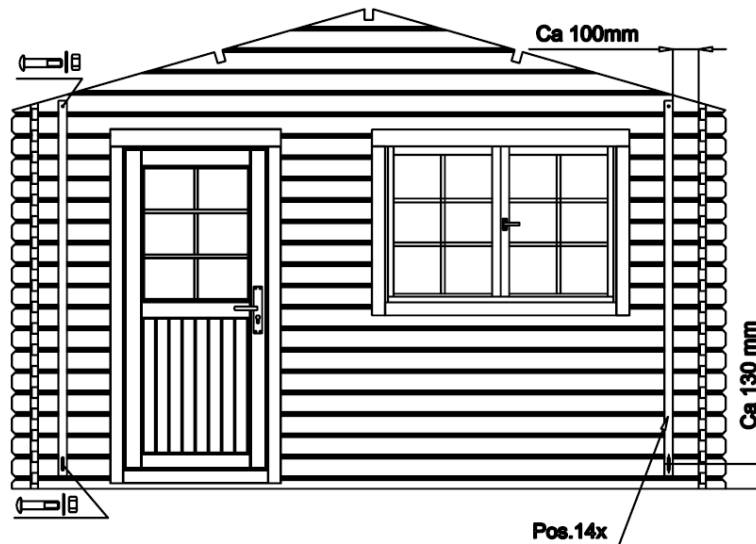

General advice:

Problem: *Gaps appear between the wall logs*

Cause: Additional details are attached to the house that do not allow wood to swell/diminish.

Solutions: If the door/window is attached to the wall logs with screws/nails, remove these screws/nails;
If the storm brace is screwed on too tightly, loosen its attachment;
If (rain water) pipes are installed on the wall, loosen their attachments;

Problem: *The doors and windows become stuck.*

Cause: The house/foundation has settled.









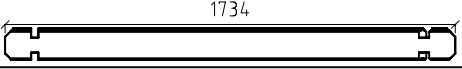
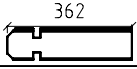
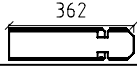
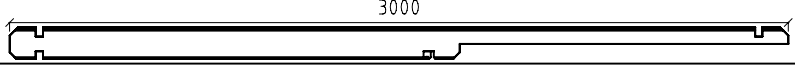
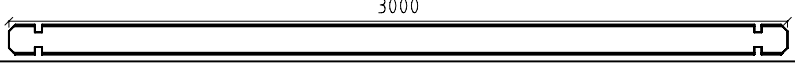
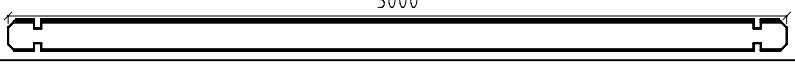
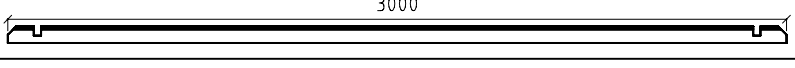
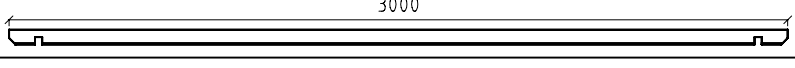
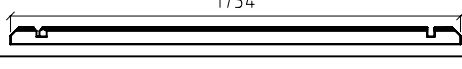
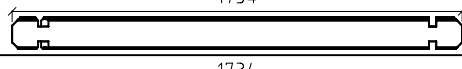
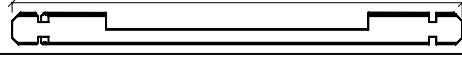
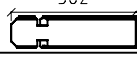
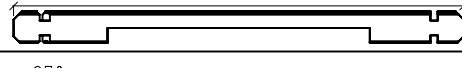

Solution: Check whether the house is level. Level the foundation joists and walls.



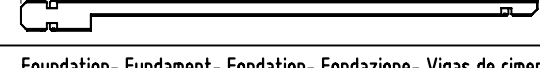
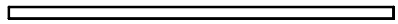
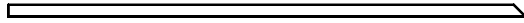









Cause: The doors and windows have swelled due to moisture.







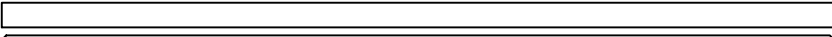













Solution: Adjust the door and window hinges; if necessary, plane the door or window narrower.



We wish you total success with the garden house installation and much joy with this house for many years to come!

Pos	SPECIFICATION-STÜCKLISTE-NOMENCLATURE-ELEMENTI-ESPECIFICACIÓN -FRJ28-3030-	Pcs	Profile (mm)	Length (mm)			
001	 1734	3	28x114	1734			
002	 362	27	28x114	362			
003	 362	14	28x114	362			
004	 3000	1	28x114	3000			
005	 3000 Without tonque	2	28x114	3000			
006	 3000	37	28x114	3000			
007	 3000	1	28x55	3000			
008	 3000	2	28x55	3000			
009	 1734	1	28x55	1734			
010	 1734	2	28x114	1734			
011	 1734	1	28x114	1734			
012	 362	13	28x114	362			
013	 1734	1	28x114	1734			
014	 270	1	28x57	270			
015	 270	16	28x114	270			
016	 270	17	28x114	270			
017	 1990	1	28x114	1990			
AR 1	Foundation- Fundament- Fondation- Fondazione- Vigas de cimentación 			90° / 90°	1	45x70	1482
AR 2	Foundation- Fundament- Fondation- Fondazione- Vigas de cimentación 			90° / 45°	1	45x70	1884
AR 3	Foundation- Fundament- Fondation- Fondazione- Vigas de cimentación 			90° / 45°	1	45x70	2305
AR 4	Foundation- Fundament- Fondation- Fondazione- Vigas de cimentación 			90° / 90°	4	45x70	2700
AR 5	Foundation- Fundament- Fondation- Fondazione- Vigas de cimentación 			90° / 90°	1	45x70	2790
AR 6	Foundation- Fundament- Fondation- Fondazione- Vigas de cimentación 			90° / 90°	1	45x70	1527
AR 7	Foundation- Fundament- Fondation- Fondazione- Vigas de cimentación 			45° / 45°	1	45x70	1786
PR 1	Purlin- Dachpfette- Arbalétrier- Arcareccio- Vigueta de tejado 				4	44x95	2350

Pos	SPECIFICATION-STÜCKLISTE-NOMENCLATURE-ELEMENTI-ESPECIFICACIÓN -FRJ28-3030-	Pcs	Profile (mm)	Length (mm)
PR 2	Purlin- Dachpfette- Arbalétrier- Arcareccio- Vigueta de tejado 	4	44x95	1258
PR 3	Purlin- Dachpfette- Arbalétrier- Arcareccio- Vigueta de tejado 	4	44x95	1258
060	Floor board - Fussbodenbrett - Madrier du plancher - Tavola pavimento - Tabla de suelo  $90^\circ / 90^\circ$ 	17	19x89	2735
061	Floor board - Fussbodenbrett - Madrier du plancher - Tavola pavimento - Tabla de suelo  $90^\circ / 45^\circ$ 	1	19x89	2735
		1	19x89	2646
		1	19x89	2557
		1	19x89	2468
		1	19x89	2379
		1	19x89	2290
		1	19x89	2201
		1	19x89	2112
		1	19x89	2023
		1	19x89	1934
		1	19x89	1845
		1	19x89	1756
		1	19x89	1667
1	19x89	1578		
070	Roof board - Dachbrett - Madrier du toit - Tavola tetto - Tabla de tejado  $47,74^\circ$ 	4	16x89	3170
		4	16x89	3008
		4	16x89	2847
		4	16x89	2684
		4	16x89	2523
		4	16x89	2361
		4	16x89	2200
		4	16x89	2035
		4	16x89	1876
		4	16x89	1714
		4	16x89	1552
		4	16x89	1390
		4	16x89	1229
		4	16x89	1067
		4	16x89	906
		4	16x89	743
		4	16x89	582
		4	16x89	420
4	16x89	258		
4	16x89	97		
15	Roof cap- Dachkappe- Finition métallique- Finitura di tetto- Caballete de tejado 	1		
153	Central fixing block- Dachspitzenbefestigungsholz- Bloc de fixation au sommet de toit Bloque fijador de tejado 	1	70x70	150
090	Eave edging - Dachrandbrett - Madrier en bordure du toit - Tavola bordo tetto - Tabla de valadizo  $45^\circ / 45^\circ$	4	19x95	3220
130	Floor beading - Fussbodenleiste - Baguette du plancher - Listello pavimento - Listón de suelo 	5	19x19	2744
160	Roof element- Dachelement- Panneau de toit- Elemento di tetto- Elemento de tejado  h=57	1	1250x1250	1767

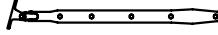
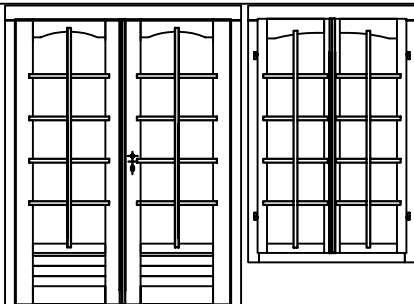
Pos	SPECIFICATION-STÜCKLISTE-NOMENCLATURE-ELEMENTI-ESPECIFICACIÓN -FRJ28-3030-	Pcs	Profile (mm)	Length (mm)
140	Storm brace - Sturmleiste - Protection contre le vent - Antivento - Protector contra tormentas 	5	25x45	2150
150	U-profile board- U-Profilleiste- Baguette profilée en U- Listello profilo ad U- Listón de perfil U 	4	44x88	900
151	U-profile board- U-Profilleiste- Baguette profilée en U- Listello profilo ad U- Listón de perfil U 	4	44x88	878
152	U-profile board- U-Profilleiste- Baguette profilée en U- Listello profilo ad U- Listón de perfil U 	4	44x88	878
300	-Fixing kit- Befestigungsset- Moyens de fixation- Materiale di fissaggio- Kit de fijación 	1		
	Cylinder- Zylinderschloss- Serrure a mortaiser- Serratura a cilindro- Bombin 	1		
	Door fittings- Türbeschlag- Ferrure- Ferramenta porta- Manilla (puerta) 	1		
	Window fittings- Fenstergriff- Poigne de la fenêtre- Maniglia finestra- Manilla (ventana) 	4		
	Nail- Nagel- Clou- Chiodo- Clavo- 1.4x40mm 	30		
	Nail- Nagel- Clou- Chiodo- Clavo- 2.5x50mm 	500		
	Bolt -Schloss-schraube -Boulon- Bullone- Perno- M8x60mm 	10		
	Washer- Dichtscheibe- Joint- Rondella- Arandela- 8x22mm 	10		
	Nut- Schraubenmutter- Écrou- Dado- Tuerca- M8mm 	10		
	Screw- Schraube- Vis- Vite- Tornillo- 3.5x50mm 	60		
	Screw- Schraube- Vis- Vite- Tornillo- 4.5x70mm 	22		
	Screw- Schraube- Vis- Vite- Tornillo- 4.5x90mm 	35		
	Nail- Nagel- Clou- Chiodo- Clavo- 4x120mm 	16		
165	Slat- Leiste- Baguette- Listello- Listón 	1	19x19	1440
	Keeper- Schliessblech- Tole- Lamiera- Aldaba de candado Screw- Schraube- Vis- Vite- Tornillo- 2.5x16mm 	1 2		
	Screw- Schraube- Vis- Vite- Tornillo- 3x16mm 	60		
	Window stop- Fensterfeststelle- Crémaillère- Fissativo finestra- Fijador de ventana- QAF240MU 	2		
TU-289 TA-287R	Door - Tür - Porte - Porta-Puerta 1440x1880 mm Window - Fenster - Fenetre - Finestra-Ventana 1003x1549 mm 	1 2		

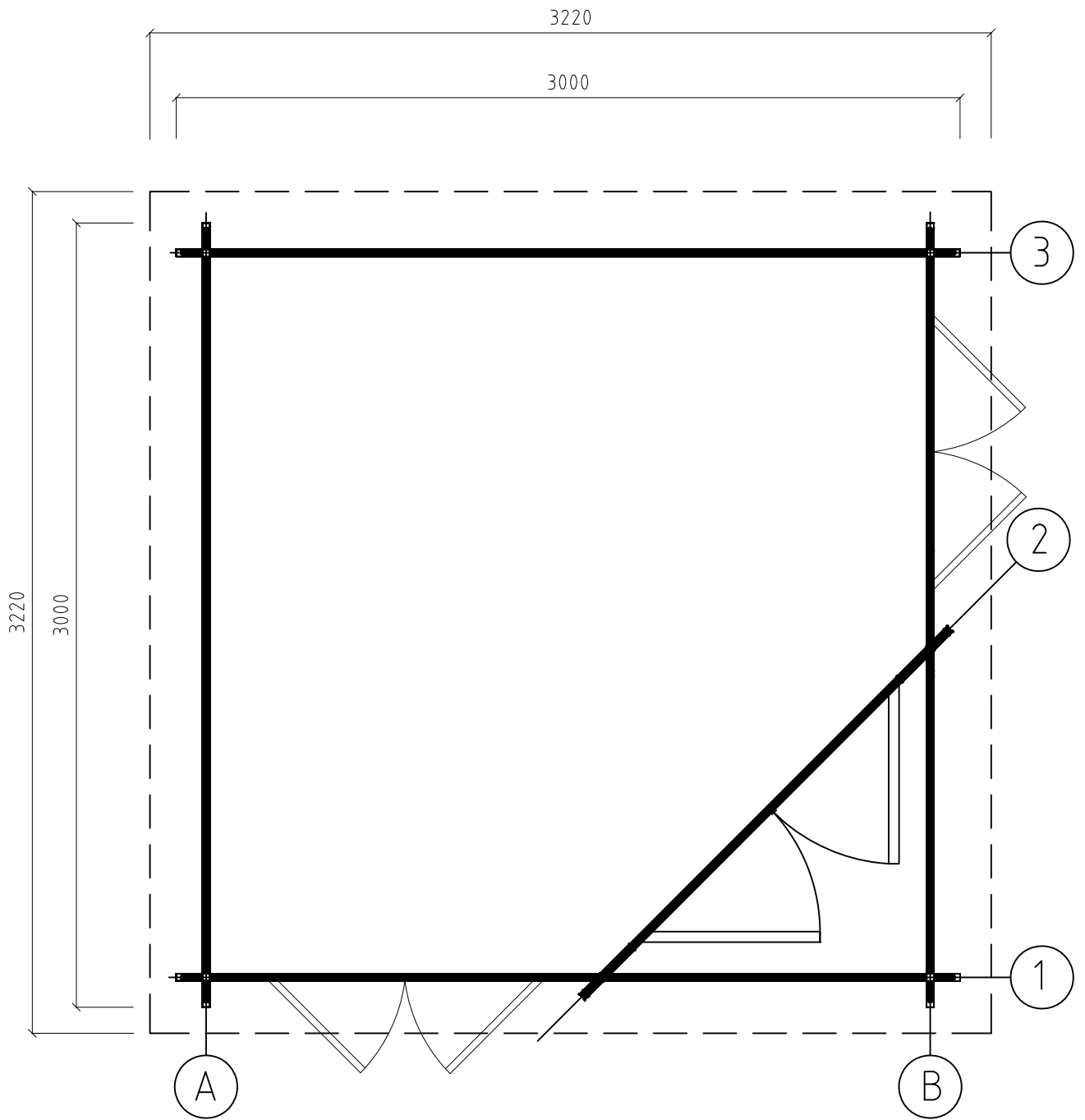

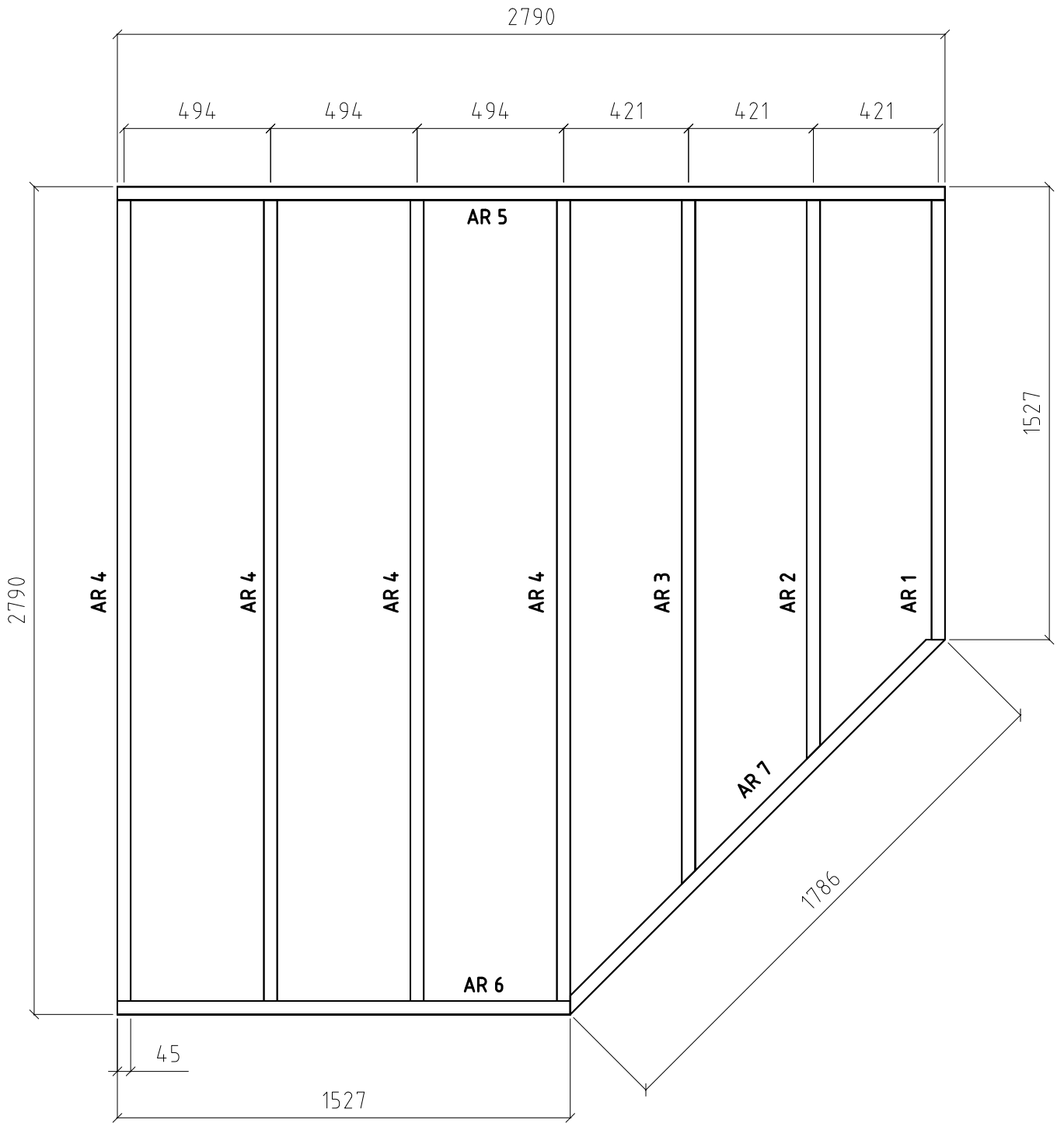

Wall 2

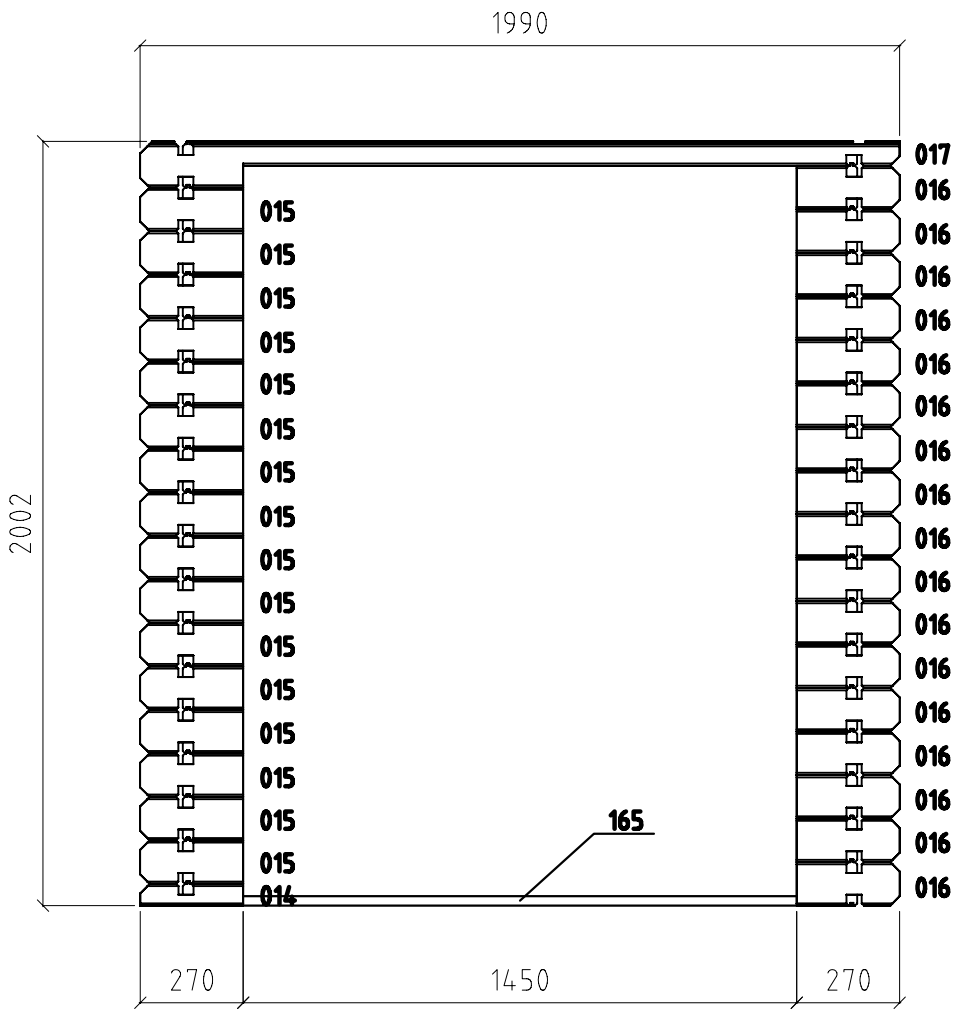

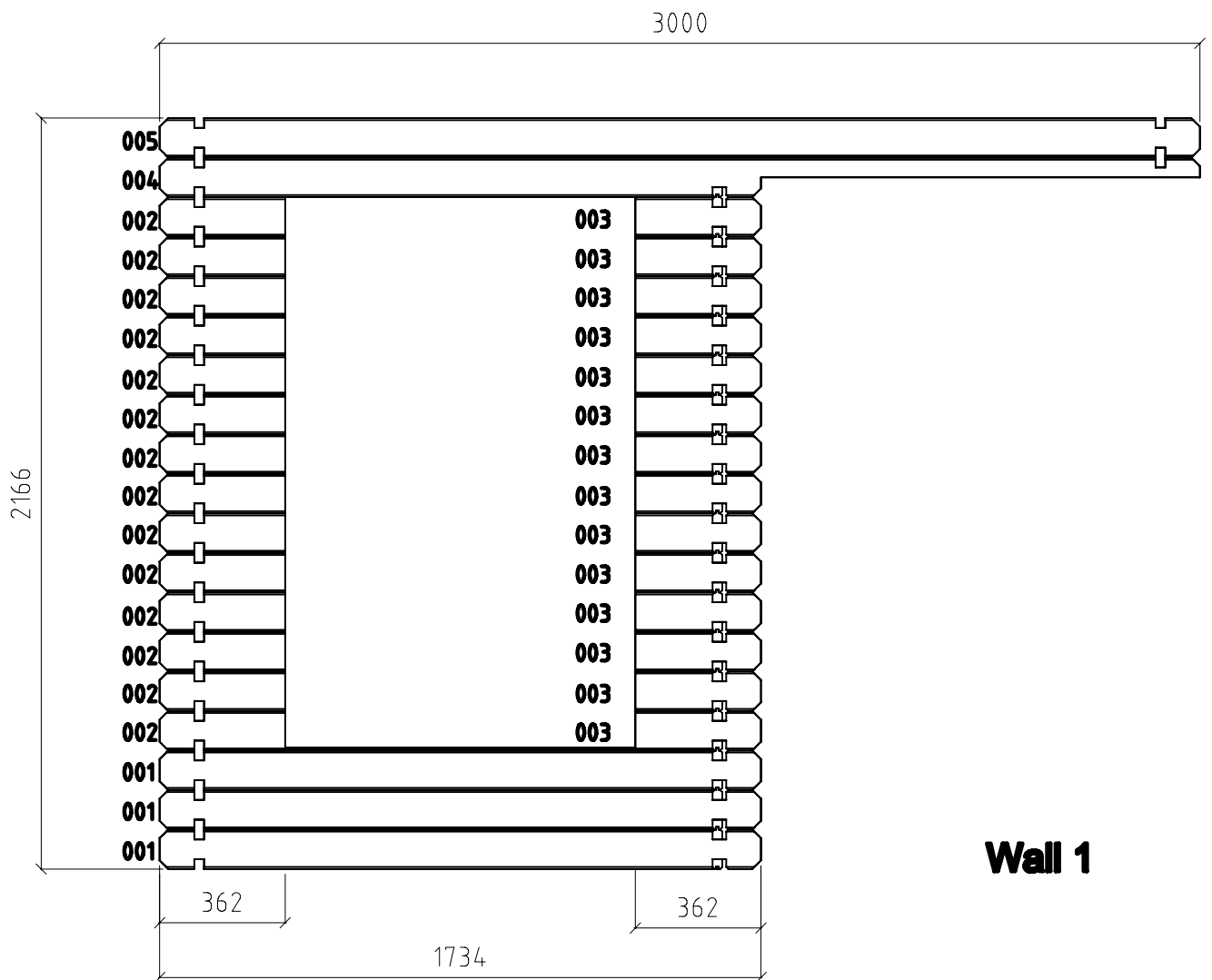

Wall 1

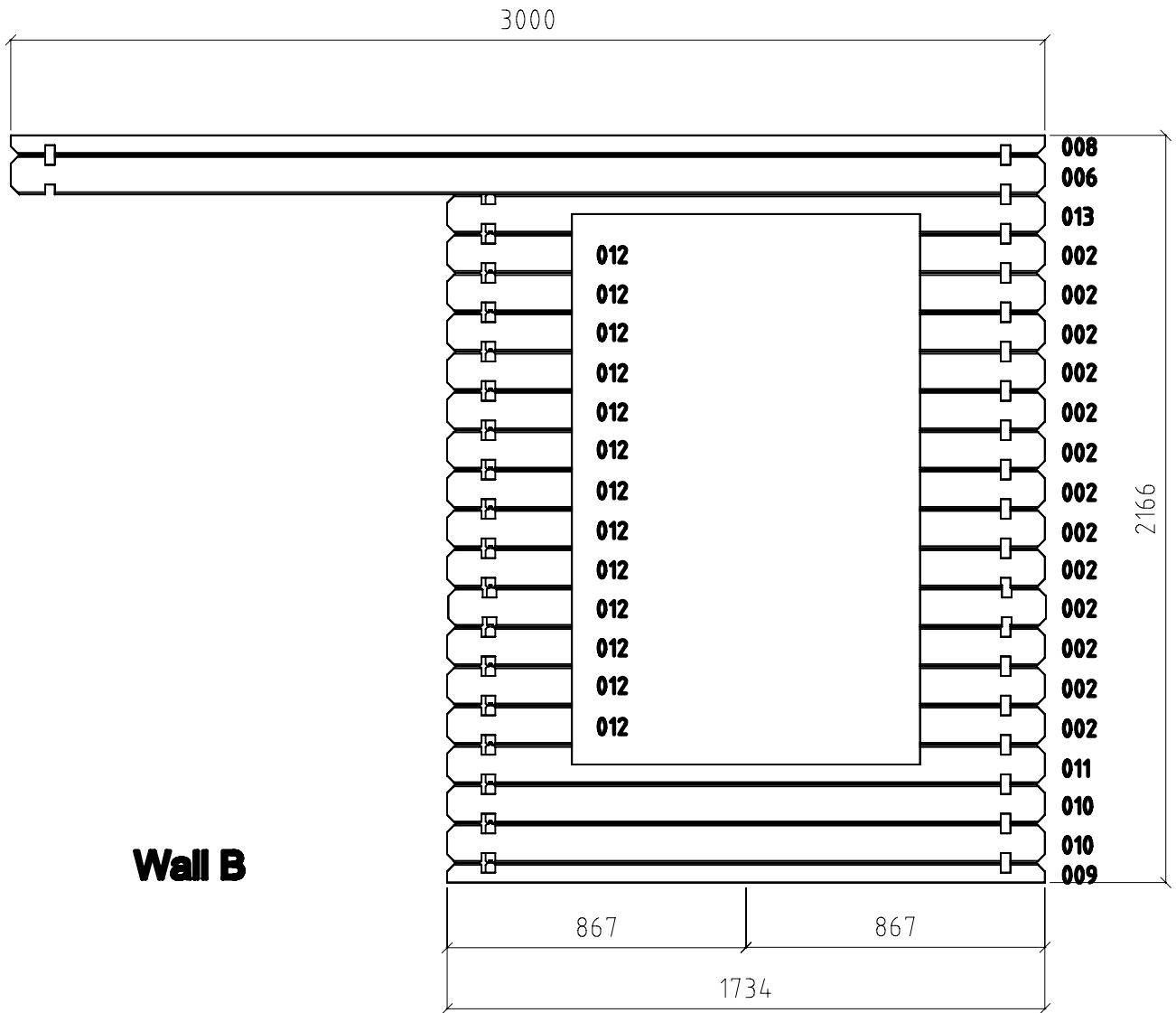

7.08.2008 12:02:24

3000

2166

Wall A

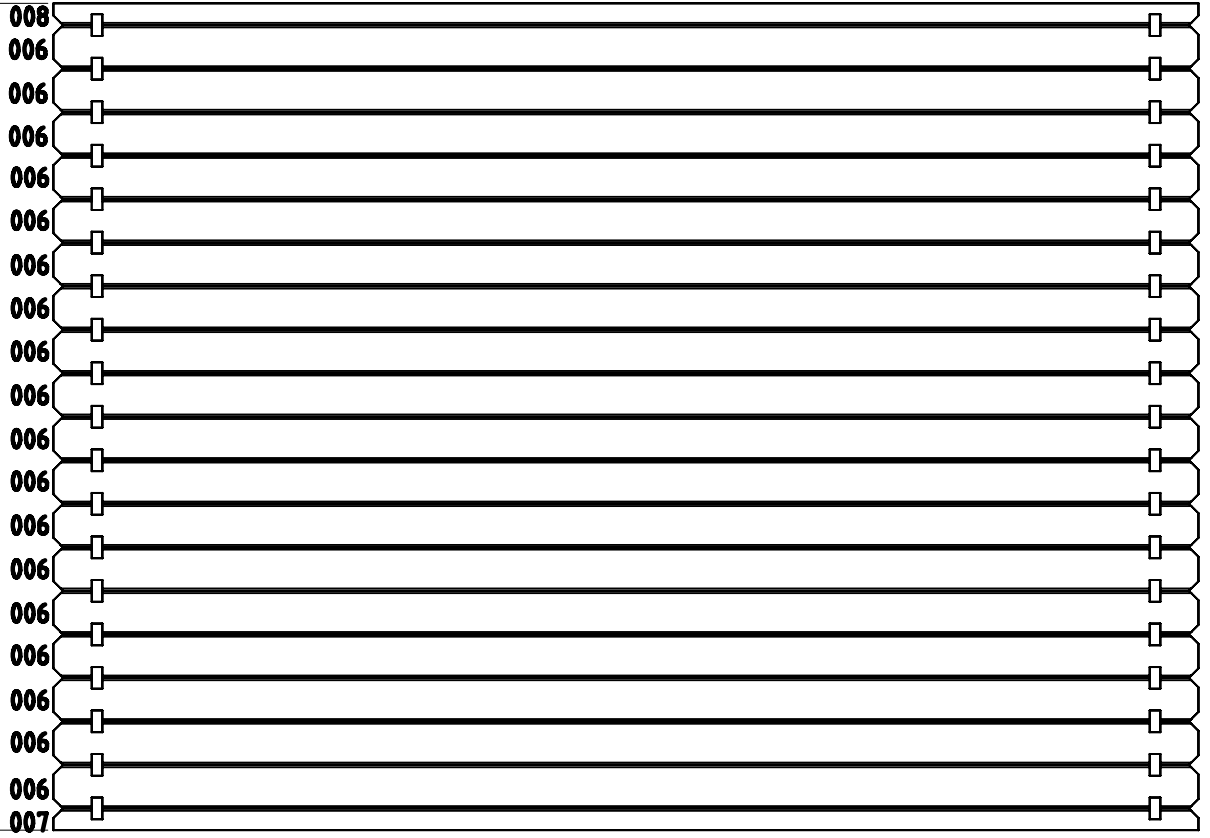

3000

2166

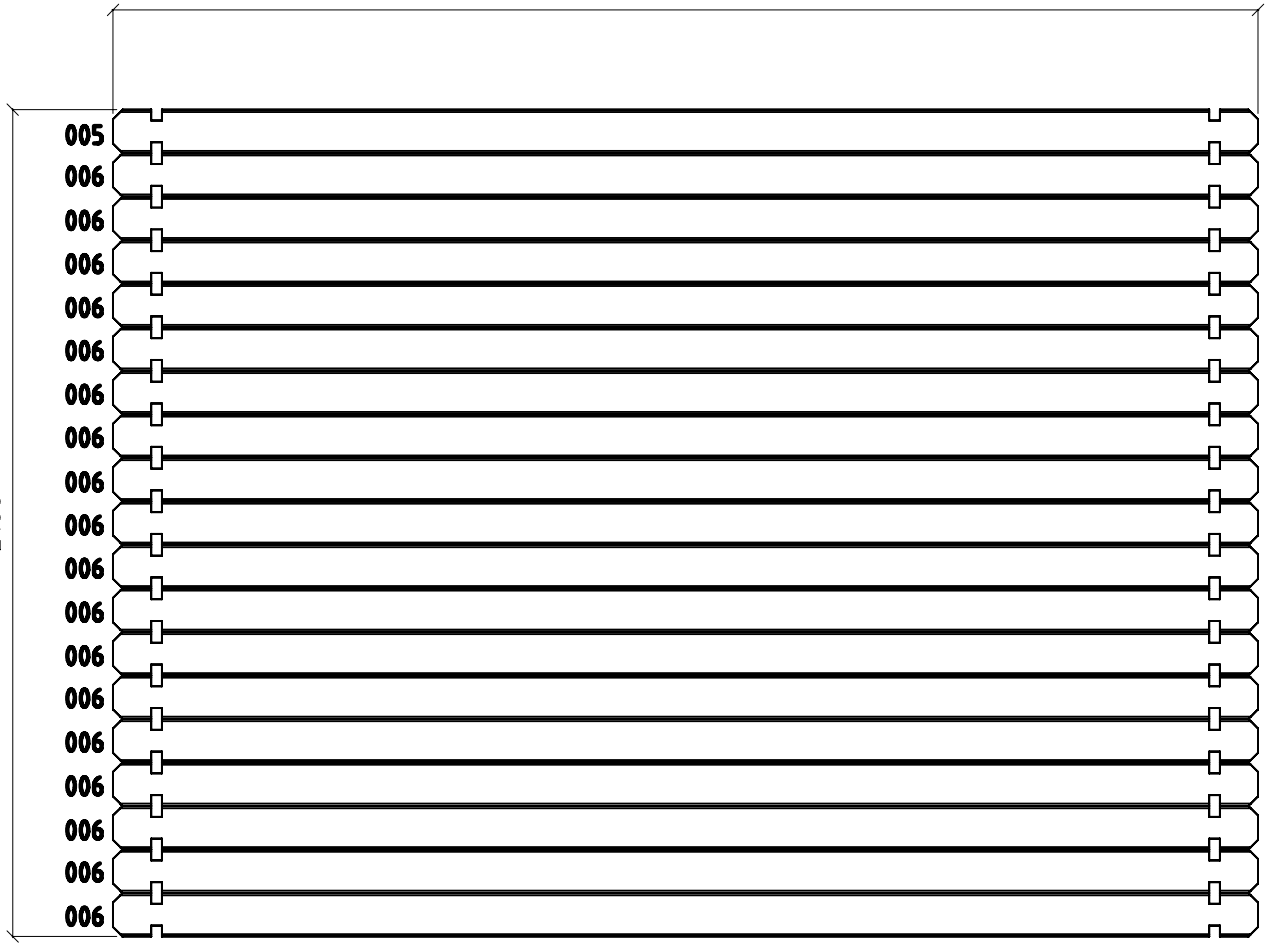

Wall 3

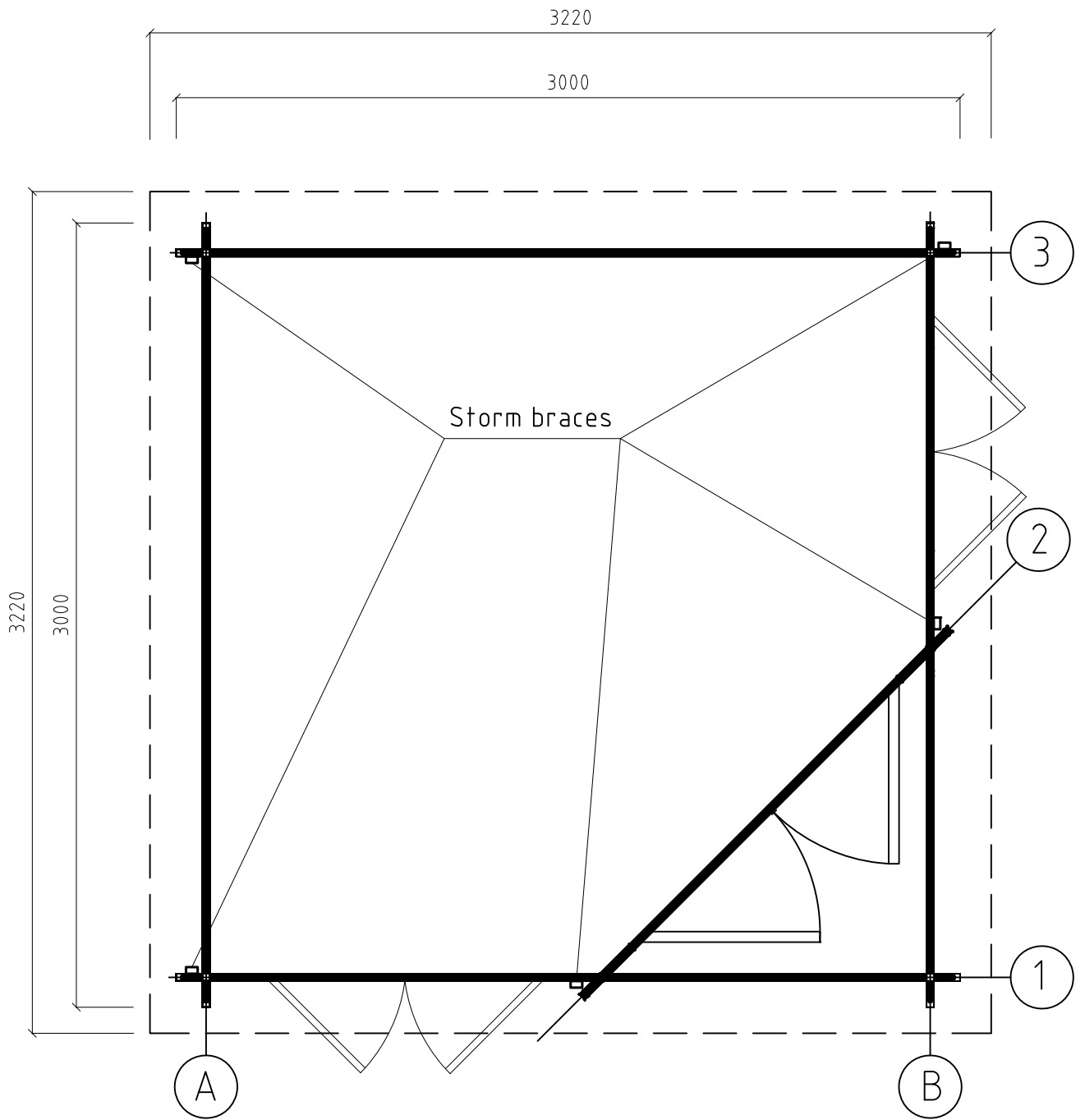

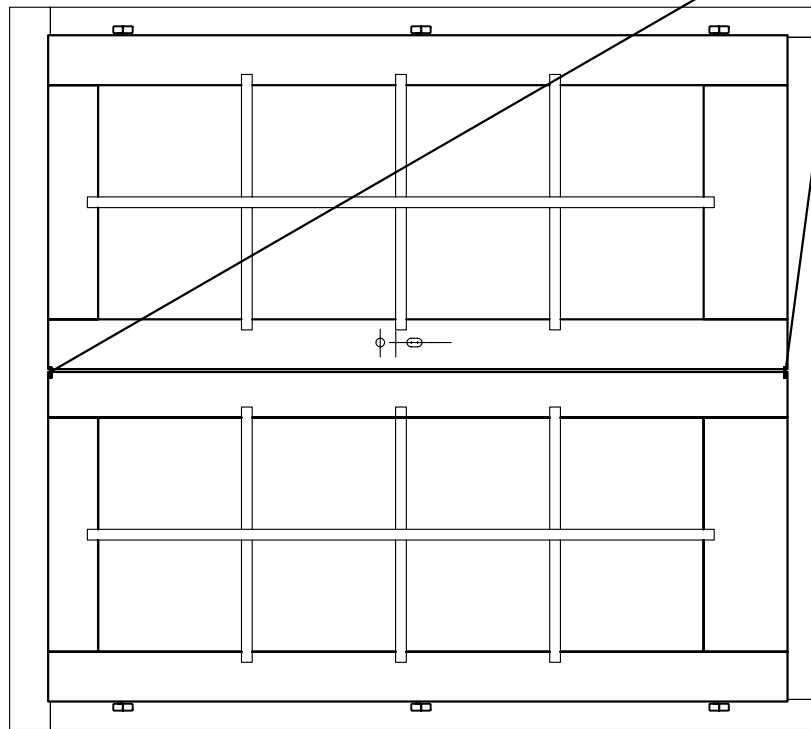

1. Drill a suitable hole.
2. Fix the keepers with 2.5x16 mm screws.
3. If the house has a metal door sill, the keeper is not needed.
1. Ein passendes Loch bohren.
2. Das Schliessblech mit 2,5x16 mm Schrauben befestigen.
3. Falls die Tür eine Edelstahlschwelle hat, brauchen sie kein Schliessblech.

1. Percer un trou approprié.
2. Fixer la tôle avec des vis de 2,5x16 mm.
3. Si la maison a un seuil de porte en inox, le tole n'est pas nécessaire.
1. Trapanare un buco adatto.
2. Fisser la lamiera con 2,5x16 mm viti.
3. Se la casa ha una porta in metallo davanzale, il lamiera non è necessario.

1. Taladra un hueco apropiado.
2. Fije las aldabas de candado con 2,5x16 mm tornillos.
3. Cuando la casa tiene protector de pisada metálico, la aldaba de candado no es necesario.

